

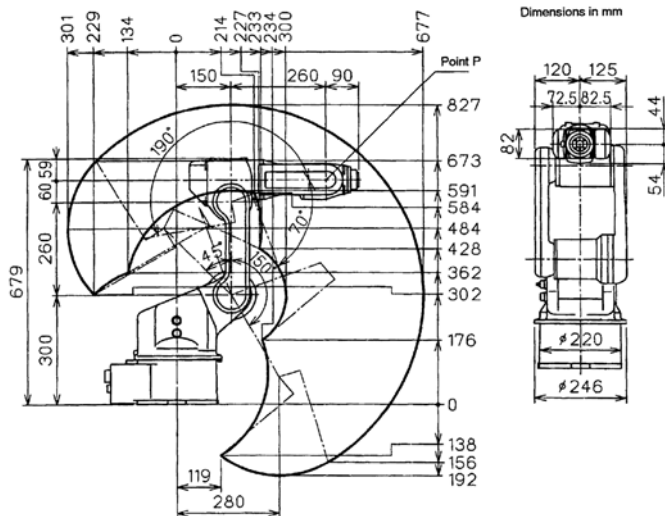

## SV3 Robot Arm Specifications

<b>Operation Mode</b>	Vertically articulated
<b>Degrees of Freedom</b>	6
<b>Payload</b>	3 kg
<b>Reach</b>	677 mm
<b>Repeatability</b>	±0.03 mm
<b>Motion Range</b>	
S-axis (turning)	±170°
L-axis (lower arm)	+ 150°, - 45°
U-axis (upper arm)	+ 190°, - 70°
R-axis (wrist)	±180°
B-axis (wrist pitch/yaw)	±135°
T-axis (wrist twist)	±350°
<b>Maximum Speed</b>	
S-axis	3.66 rad/s, 210°/s
L-axis	2.97 rad/s, 170°/s
U-axis	3.93 rad/s, 225°/s
R-axis	5.23 rad/s, 300°/s
B-axis	5.23 rad/s, 300°/s
T-axis	7.33 rad/s, 420°/s
<b>Allowable Moment</b>	
R-axis	5.39 N·m (0.55 kgf·m)
B-axis	5.39 N·m (0.55 kgf·m)
T-axis	2.94 N·m (0.3 kgf·m)
<b>Allowable Inertia (CD<sup>2</sup>/4)</b>	
R-axis	0.1 kg·m <sup>2</sup>
B-axis	0.1 kg·m <sup>2</sup>
T-axis	0.03 kg·m <sup>2</sup>
<b>Mass</b>	30 kg
<b>Ambient Conditions</b>	
Temperature	0° - 45°
Humidity	20 - 80% RH (non-condensing)
Vibration	Less than 0.5 G



SV3 Dimensions and Working Envelope - Side View

## Controller-BRC Specifications

<b>Case</b>	Free-standing, enclosed frame
<b>Weight</b>	17 kg
<b>Dimensions</b>	W=289 mm H=433 mm D=317 mm
<b>Cooling</b>	Indirect
<b>Operating Temp.</b>	0° - 40°
<b>Relative Humidity</b>	less than 90%; non-condensing
<b>AC Power Input</b>	200 - 230V AC; +10%,-15%; 50 Hz or 60Hz
<b>Grounding</b>	Less than 100 Ohm
<b>Communication</b>	2 RS232 channels
<b>Inputs/Outputs</b>	16 inputs optically insulated, 5 mA4 relays output 500 mA, normally open contact 12 insulated transistor output 24 V, 50 mA, optional additional 32 input, 32 output.
<b>Motor Driver</b>	AC Servos
<b>Position Feedback Devices</b>	Absolute encoder, 16 bits/turn resolution (Return to Home or Homing not required)
<b>Number of Axes</b>	6 for robot; one additional axis optional
<b>Acceleration</b>	S-curve profile (smooth acceleration)
<b>User Memory</b>	400 programs; 5000 program lines; 7000 positions (standard configuration)
<b>Programming Language</b>	ACL-Win; Advanced Control Language. Full multi-tasking, up to 40 concurrent tasks for robot and cell control; Provides wide set of instructions for trajectory and torque control. Automatic programs for Restart; Emergency; Background Safety
<b>Program Editing</b>	On-line and off-line by ACL-Win software
<b>Axis Servo Control</b>	Fully digital with absolute encoder and brake control; 0.125µ position loop; Emergency stop (limit switches, emergency switch, errors); Control parameters in EEPROM of each axis driver
<b>Trajectory Control</b>	PTP, Joint, linear and circular interpolation; Continuous path with all movement combinations; On-the-fly change of speed, acceleration and trajectory
<b>Torque Control</b>	User definable upper and lower torque limits (value and sign)
<b>Teach Pendant (optional)</b>	Jogging, teaching positions, testing trajectory, running programs; 25 multifunction keys; 4 line display; Emergency and Dead Man switches

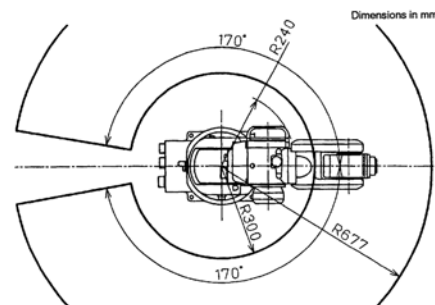

SV3 Dimensions and Working Envelope - Top View

Specifications are subject to change without prior notice.

cat# 100583 rev.B



444 East Industrial Park Drive, Manchester, NH 03109-5317, USA  
 Tel: (603) 625-8600, (800) 777-6268 Fax: (603) 625-2137  
 email: info@intelitek.com website: www.intelitek.com